

样品承认书

Sample Approval Sheet

产品类别(Product type):LED		
产品名称(Product name):5mm 圆头共阳红黄绿双色发光二极管		
产品编号(Part No.):WEJ5090W-R2H0-BA-1		
样品编号(Sample No.):		
承认书编号(Acknowledgement Numbers):		
签核 (Signatures)		
核准(Approved)	审核(Checked)	制定(Drawn)
王娟	王艳	孙飞

客户 (Customer)		
公司名称(Corporation):		
物料编码(Material No.):		
物料名称(Part No.):		
客户确认 (Customer Signatures)		

地址: 深圳市光明新区公明街道玉律社区第六工业区 21 栋

Factory Add:21st Bld yulv 6th industrial Park,Gen yu Road gongming New District,Shenzhen, Guang Dong China

电话(Tel): 0755-29785600 29785800 传真(Fax): 0755-29785100 联系人(Contact Person):

网址(Web Site): www.wej.cn

Feature

- *Low power consumption
- *Long life-solid state reliability
- *Available on tape and reel
- *RoHS compliant

特征

- *低能耗
- *寿命长
- *易于装贴
- *符合 RoHS 要求

Package outline dimensions (产品外型尺寸)

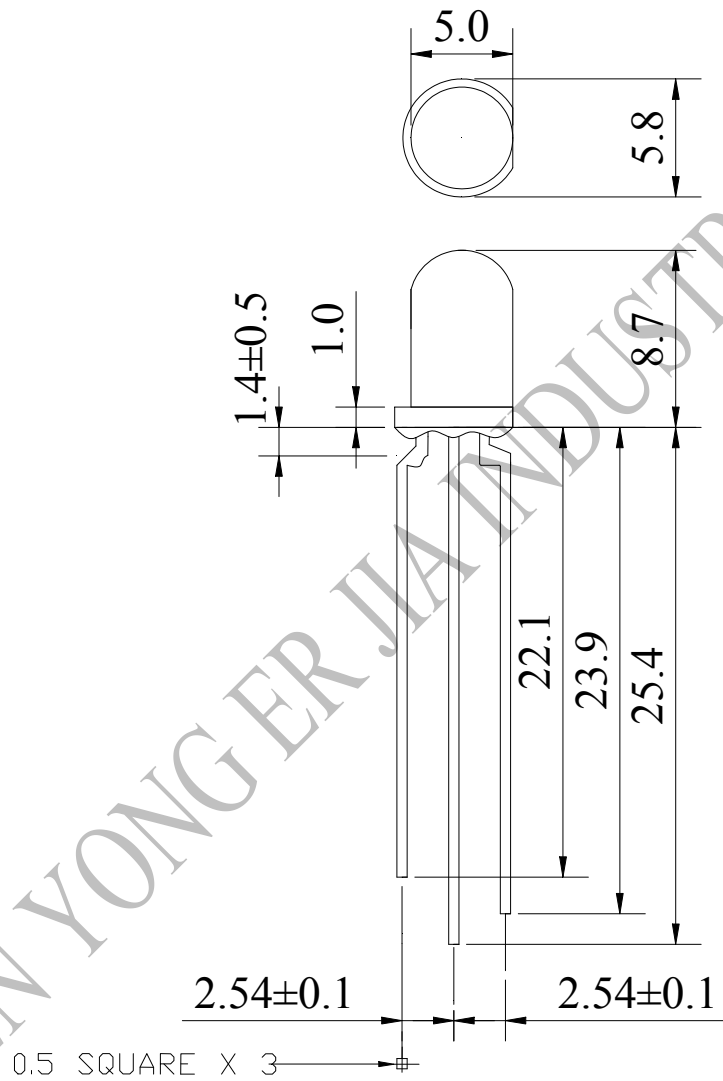

Note:

1. All dimensions are in millimeters;
2. Tolerance is ±0.25 unless otherwise noted;
3. Lead spacing is measured where the leads emerge from the package;
4. The specifications of the product may be modified for improvement without notice.

Electrical characteristics data sheet

Selection Guide (选用指示)

Part No. (产品型号)	Emitted Color (发光颜色)		Resin color (胶体颜色)	Viewing Angle (发光角度) 2θ _{1/2}
WEJ5090W-R2H0-BA-1	红色	黄绿色	白色扩散	75°

Absolute Maximum Ratings at Ta=25°C (极限参数)

Parameter (项目)	Symbol (符号)	Value (数值)		Unit (单位)
		R	H	
Power dissipation (功率消耗)	Pd	80	80	mW
DC Forward Current (正向电流)	If	30	30	mA
Peak Forward Current ⁽¹⁾ (峰值电流)	Ifp	100	100	mA
Reverse Voltage (反向电压)	Vr	5	5	V
Electro-Static-Discharge (HBM)	ESD	2000	2000	V
Operating Temperature (操作温度)	Topr	-25to+85		°C
Storage Temperature (储存温度)	Tstg	-40to+100		°C
Lead Solder Temperature ⁽²⁾ (焊接温度)	Tsol	250 for 5sec		°C

Notes:

- 1.1/10 duty cycle,0.1ms pulse width
2.2mm below package base.

Electrical/Optical Characteristics Ta=25°C (电子光学特性)

Parameter (参数)	Symbol (符号)	Condition (条件)	Emitting Color (发光颜色)	Value (数值)			Unit
				Min.	Typ.	Max.	
Forward voltage (正向电压)	Vf	If=20mA	R	---	2.0	2.4	V
			H	---	2.2	2.4	
Luminous intensity (发光强度)	Iv	If=20mA	R	45	120	---	mcd
			H	10	35	---	
Dominant wavelength (主波长)	λd	If=20mA	R	630	640	645	nm
			H	564	570	576	
Peak wavelength (峰值波长)	λp	If=20mA	R	---	655	---	nm
			H	---	565	---	
Reverse current (反向电流)	Ir	Vr=5V		---	---	1	μA

Notes:

- 1.Forward Voltage:±0.1V
2.Wavelength: ±1.5nm
3.Luminous Intensity: ±10%

Typical Electro-Optical Characteristics Curves

FORWARD CURRENT VS.APPLIED VOLTAGE

电流与电压的关系图

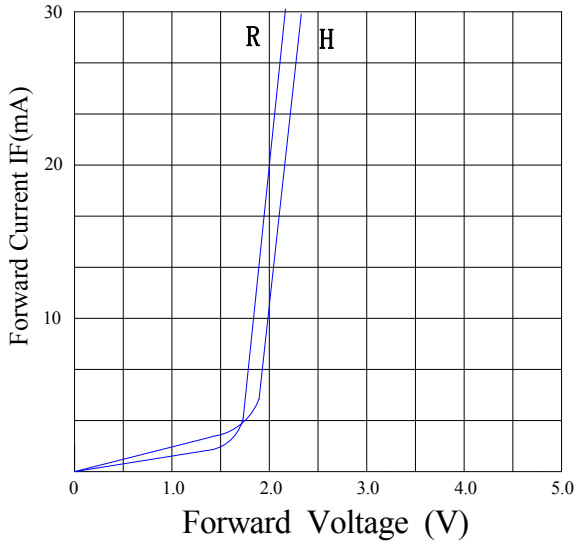

FORWARD CURRENT VS. LUMINOUS INTENSITY

电流与光强的关系图

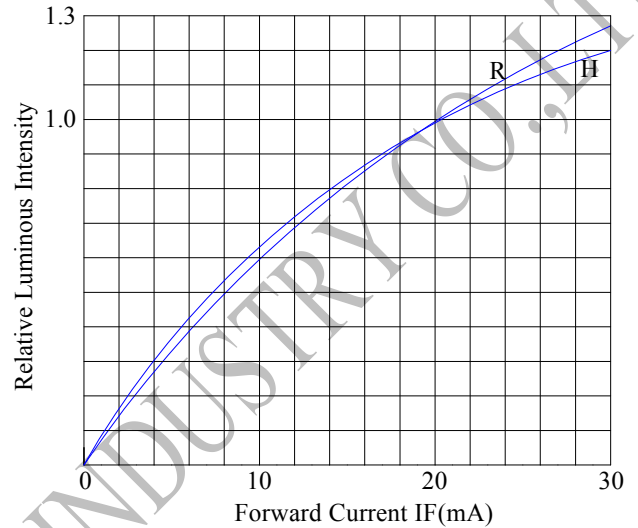

AMBIENT TEMPERA TURE VS.FORWARD CURRENT

电流与温度的关系图

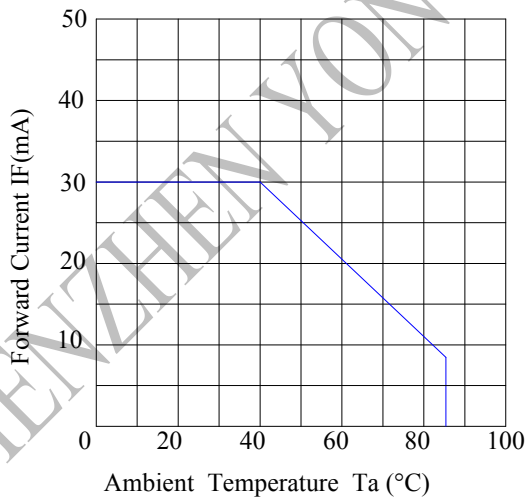

RADIATION DIAGRAM

视角图

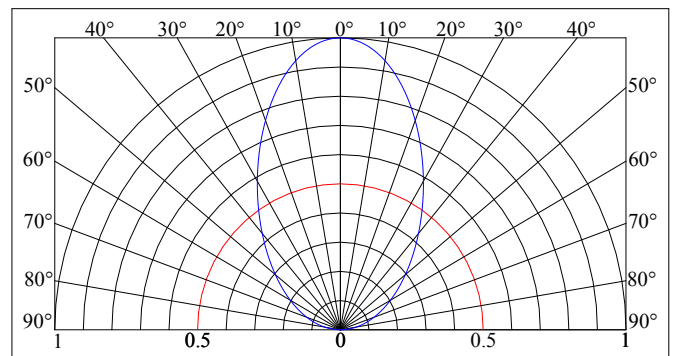

Precautions(使用注意事项)

1.Storage (储存)

Under the storage conditions of 30°C or less and humidity less than 60%RH, the LEDs can be storage for 3months. Storage in a sealed container with moisture absorbent material can prolong the storage time to a certain extent bad storage conditions may cause the lead frames to corrode or degradation of LED characteristics. It is recommended that the LEDs be used as soon as possible.

在温度低于 30°C，湿度不高于 60%RH 的条件下，产品保存期限为 3 个月。将产品保存在密封的容器中并附带干燥剂可以在一定程度上延续产品的储存日期。不良的储存条件会导致产品引脚的腐蚀或产品性能的改变。

2. Static electricity (静电)

Static electricity of surge voltage damages the LED .Damaged LED will show some unusual chrematistics such as the forward voltage becomes lower or the LED do not light at the low current even not light. All devices equipment and machinery must be properly grounded. At the same time, it is recommended that wrist Bands or anti-electrostatic gloves anti-electrostatic containers be used when dealing with the LED.

静电和电涌会导致产品特性发生改变，例如正向电压降低等，如果情况严重甚至会损毁产品，所以在使用时必须采取有效的防静电措施。所有相关的设备和机器都应该正确的接地，同时必须采取其他防静电和电涌的措施。使用防静电手环，防静电垫子，防静电工作服，工作鞋，手套，防静电容器，都是有效的防止静电和电涌的措施。

3. Design Consideration (设计建议)

When designing a circuit, the current through each LED must not exceed the absolute maximum rating specified for each LED .In the meanwhile , resistors for protection should be applied otherwise slight voltage shift will cause big current change, bum out may happen.

Thermal Design is paramount important in because heat generation may result in the Characteristics decline, such as brightness decreased, Color changed and so on. Please consider the heat generation of the LED when making the system design.

设计电路时，通过 LED 的电流不能超过规定的最大值，同时还需要使用保护电阻，否则微小的电压变化将会引起较大的电流变化，可能导致产品损毁。

LED 的特性容易因为自身的发热和环境的温度的改变而发生改变。温度的升高会降低 LED 的发光效率，影响发光颜色等，所以在设计时应充分考虑散热的问题。

4. Lead Forming (支架整形)

Any lead forming must be done before soldering, not during or after soldering. When forming leads ,the leads should bent at a point at least 3mm from the base of the expose bulb. Bending at the same point twice or even more should be avoided.

Please use proper tools to hold and bent the leads, do not use the base of the lead frame as a fulcrum during lead forming .Bending stress to the base of the lead frame may cause characteristics change on LED or even break it.

Just for the same reason, when mounting the LED on to printed circuit board, the holes on the circuit board should be exactly aligned with the leads of the LED.

支架的整形必须在焊接之前进行。整形时，支架的弯曲位置必须至少在封装树脂底部 3mm 处，同时避免对同一位置进行多次的弯曲。整形时，请使用合适的工具固定支架，避免对树脂施加压力。特别是不能管脚与树脂的连接部分作为支点，这样产生的应力会直接对产品内部的发光结构造成损伤，导致产品特性的改变甚至损毁。基于同样的原因，在装配产品的时候，PCB 板上焊孔间的距离必须于产品的管脚间距严格匹配。

5. Soldering (焊接)

Be careful because damages always caused during soldering. Please note that stress to the leads and expose bulb should be avoided during soldering particularly when heated. When soldering, leave certain distance from soldering joint to base, the distance is determined by different soldering techniques. It is recommended that soldering be performed based on the following conditions.

焊接过程中的不慎操作将会引起产品的损坏，请务必注意。焊接过程中应避免对产品支架或封装部分施加压力。焊接时，请保证焊接位置与封装树脂底部有一定的距离，该距离因不同的焊接方法而有所不同，请参照以下推荐焊接条件。

推荐焊接条件 Recommended Soldering Conditions:

波峰焊接 DIP Soldering		烙铁焊接 Hand Soldering	
预热 Pre-Heat	100°C Max.60 sec.Max	焊接温度 Temperature	350°C Max
温度 Dipping Time	250°C Max.5 secMax	焊接时间 Soldering Time	3 Sec. Max
焊接位置 Dipping Position	2mm ,Min 与树脂底部的距离 From soldering joint to base	焊接位置 Soldering Position	2mm ,Min 与树脂底部的距离 From soldering joint to base