

# 样品承认书

## Sample Approval Sheet

产品类别(Product type):SMD		
产品名称(Product name):5050 白光 (5050 White SMD LED)		
产品编号(Part No.): WEJT50AW7-JNIP01		
样品编号(Sample No.):		
承认书编号(Acknowledgement Numbers):		
<b>签核 (Signatures)</b>		
<b>核准(Approved)</b>	<b>审核(Checked)</b>	<b>制定(Drawn)</b>
王娟	王娟	王艳

<b>客户 (Customer)</b>		
公司名称(Corporation):		
物料编码(Material No.):		
物料名称(Part No.):		
<b>客户确认 (Customer Signatures)</b>		

地址:深圳市光明新区公明街道玉律社区第六工业区 21 栋

Factory Add: 21<sup>st</sup> Bld., 6<sup>th</sup> Industrial Park, Yulu Community, Genyu Rd., Guangming New District, Shenzhen, China

电话(Tel):0755-29785600 29785800 传真(Fax):0755-29785100 联系人(Contact Person):

网址(Web Site): [www.wej.cn](http://www.wej.cn)

**Feature**

- \*Low power consumption
- \*Long life-solid state reliability
- \*Available on tape and reel
- \*RoHS compliant

**特征**

- \*低能耗
- \*寿命长
- \*易于装贴
- \*符合 RoHS 要求

**Package outline dimensions (产品外型尺寸)**

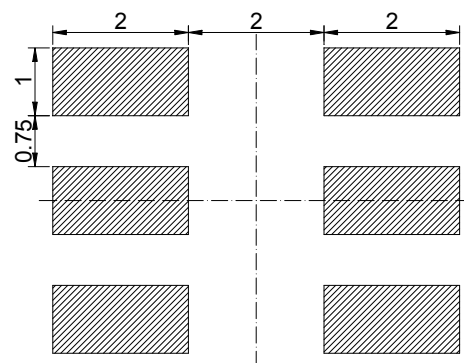
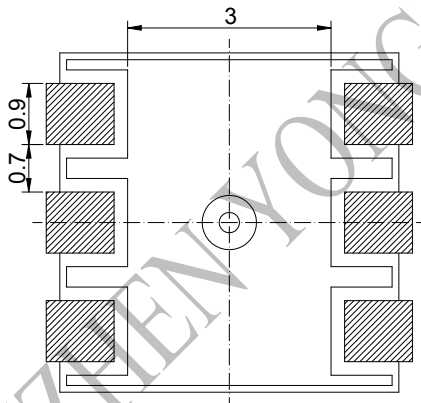
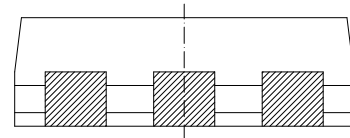
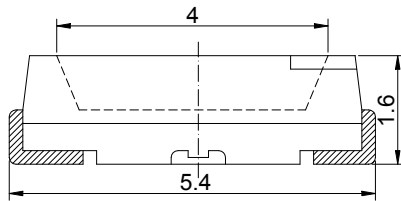
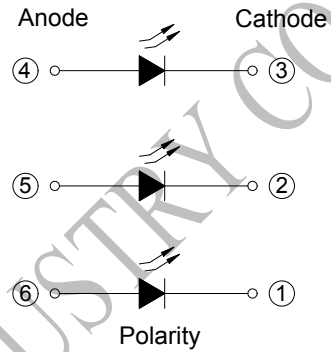
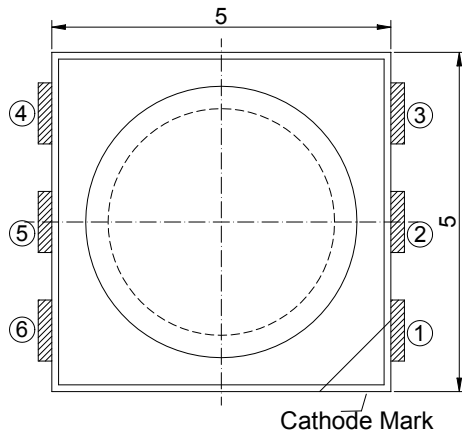

Recommended Soldering Pad

**Note:**

1. All dimensions are in millimeters(mm);
2. X.X is +/-0.1mm,X.XX is +/- 0.05mm unless otherwise noted;
3. The device has a single mounting surface, the device must be mounted according to the specifications.
4. The specifications of the product may be modified for improvement without notice.

## Electrical characteristics data sheet

### Selection Guide (选用指示)

Part No. (产品型号)	Emitted Color (发光颜色)	Resin color (胶体颜色)	Viewing Angle (发光角度) 2θ <sub>1/2</sub>
WEJT50AW7-JNIP01	白光 (White)	黄色 (Yellow)	120

### Absolute Maximum Ratings at Ta=25°C (极限参数)

Parameter (项目)	Symbol (符号)	Value (数值)	Unit (单位)
Power dissipation (功率消耗)	Pd	204	mW
DC Forward Current (正向电流)	If	60	mA
Peak Forward Current <sup>(1)</sup> (峰值电流)	Ifp	300	mA
Reverse Voltage (反向电压)	Vr	5	V
Electro-Static-Discharge <sup>(2)</sup> (HBM)	ESD	1000	V
Operating Temperature (工作环境温度)	Topr	-25to+85	°C
Storage Temperature (储存温度)	Tstg	-40to+100	°C
Lead Solder Temperature (焊接温度)	Tsol	260 for 5sec	°C

#### Notes:

- 1/10 duty cycle, 0.1ms pulse width;
2. The products are sensitive to static electricity and must be carefully taken when handling products.

### Electrical/Optical Characteristics Ta=25°C (电子光学特性)

Parameter (参数)	Symbol (符号)	Condition (条件)	Value (数值)			Unit
			Min.	Typ.	Max.	
Forward voltage (正向电压)	Vf	If=60mA	2.8	3.0	3.4	V
Luminous flux (光通量)	Φ	If=60mA	22	23	---	lm
Chromaticity coordinate (色坐标)	X	If=60mA	---	0.31	---	---
	Y	If=60mA	---	0.33	---	---
Color temperature (色温)	Tc	If=60mA	5500	6000	6500	K
Color rendering index (显色指数)	Ra	If=60mA	70	---	---	%
Reverse current (反向电流)	Ir	Vr=5V	---	---	1	μA

#### Notes:

1. Forward voltage: ±0.1V ;
2. Color temperature: ±5%;
3. Luminous Flux: ±10%.

**Typical Electro-Optical Characteristics Curves**

**FORWARD CURRENT VS. FORWARD VOLTAGE**

电流与电压的关系图

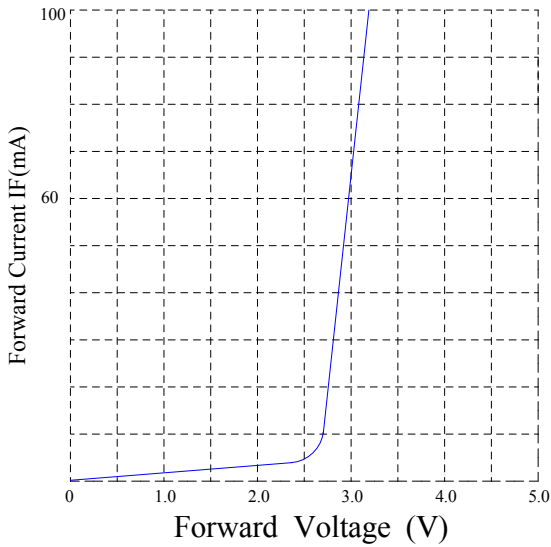

**FORWARD CURRENT VS. LUMINOUS INTENSITY**

电流与光强的关系图

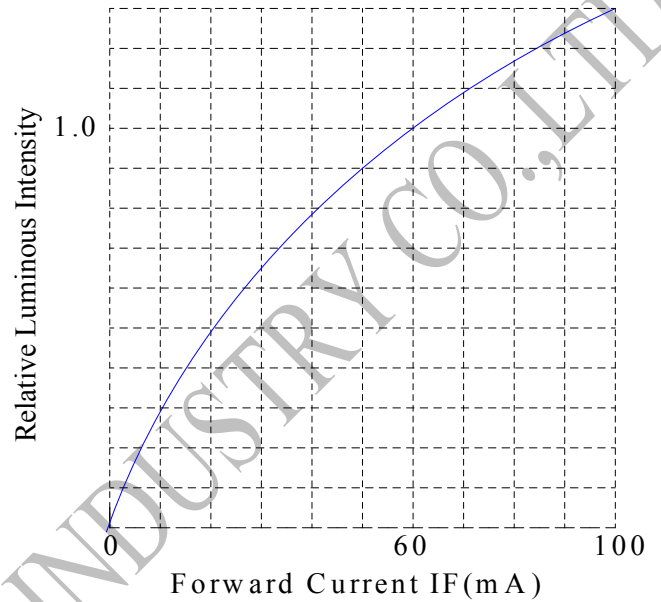

**AMBIENT TEMPERATURE VS. FORWARD CURRENT**

电流与温度的关系图

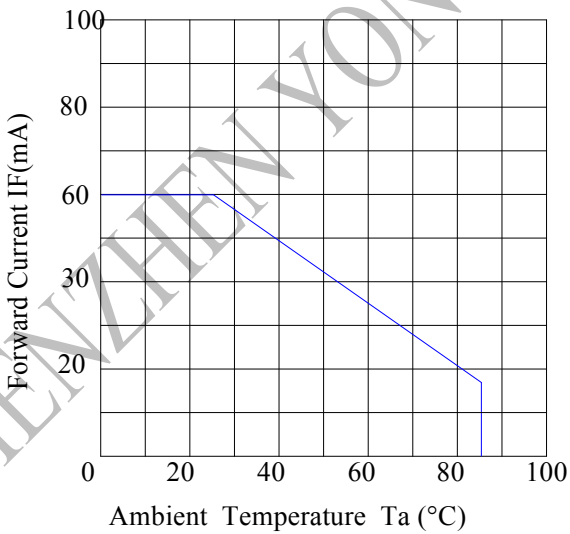

**RADIATION DIAGRAM**

视角图

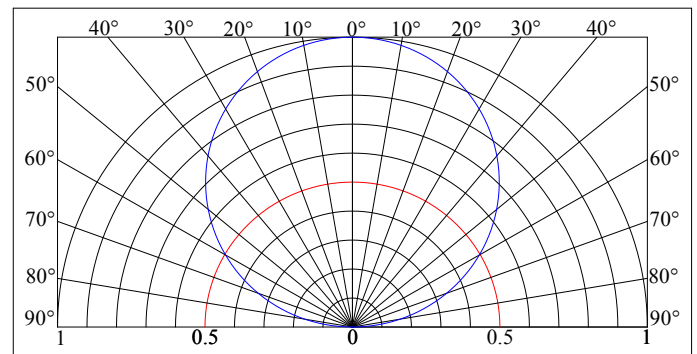

### Bin Range of Technical Data Sheet

Voltage code (电压等级)			Intensity code(光强等级)		
group	Forward voltage		group	Luminous Flux	
	Min (v)	max (v)		Min (lm)	max (lm)
J	2.8	3.0	15	22	24
K	3.0	3.2	16	24	26
L	3.2	3.4			

### Bin Range of Chromaticity Coordinates Block<色坐标分 BIN 等级>

The CIE 1931 Chromaticity diagram

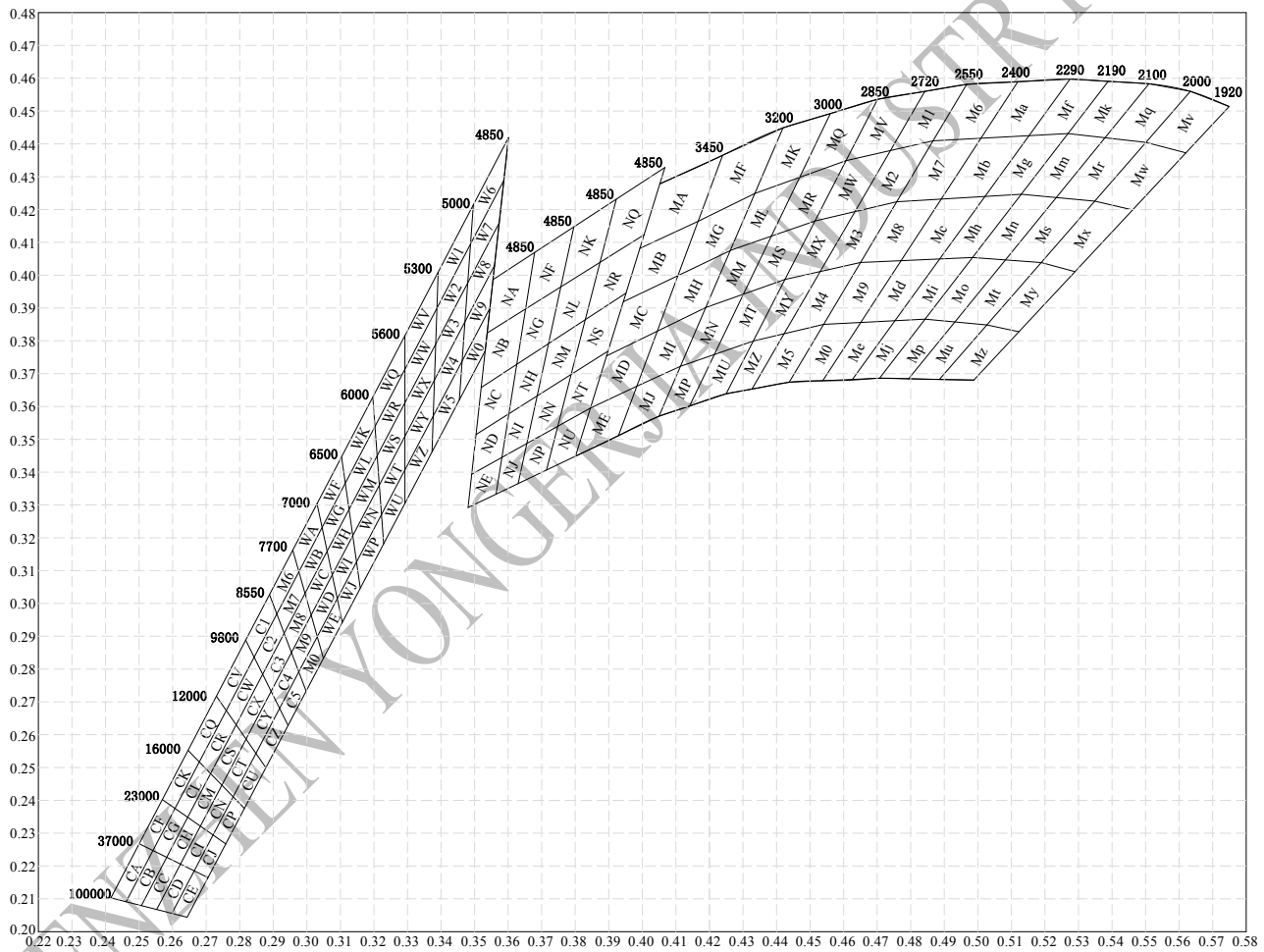

**Notes:**

- 1、Tolerance of forward voltage for each Bin limit is  $\pm 0.1v$ .
- 2、Tolerance of luminous intensity for each Bin limit is  $\pm 10\%$ .
- 3、Tolerance of X/Y for each Bin limit is  $\pm 0.005$ .

**Reliability Test Items and Conditions(可靠性试验及条件)**

1、Test items and result(测试项目及结果)

Test Item 测试项目	Ref. Standard 参考标准	Test Condition 测试条件	Note 记录	Number of Damaged 受损数量
Resistance to Soldering Heat (耐热测试)	JESD22-B106	Tsld=260°C,10sec	2 times	0/100
Temperature Cycle (冷热循环)	JESD22-A104	-40°C 30min ↓↑ 5min 100°C 30min	100 cycle	0/100
Thermal Shock (冷热冲击)	JESD22-A106	-40°C 15min ↑↓ 100°C 15min	100 cycle	0/100
Power temperature Cycling (高低温点亮循环测试)	JESD22-A105	On 5min -40°C>15min ↑↓↑↓<15min Off 5min 100°C>15min	100 cycle	0/100
High temperature Storage (高温储存)	JESD22-A103	Ta=100°C	1000 hrs	0/100
Low temperature Storage (低温储存)	JESD22-A119	Ta=-40°C	1000 hrs	0/100
Lift Test (寿命测试)	JESD22-A108	Ta=25°C IF=20mA	1000 hrs	0/20
High Humidity Heat Lift Test (高温高湿老化)	JESD22-A101	60°C RH=90 % IF=20mA	1000 hrs	0/20

2、Criteria for judging damage (受损失效判定标准)

Item 项目	Symbol 符号	Test Conditions 测试条件	Criteria for Judgment 判断标准	
			Min 最小	Max 最大
Forward voltage 正向电压	VF	IF=60mA	--	U.S.L*)×1.1
Reverse current 反向电流	IR	VR=5V	--	U.S.L*)×2.0
Luminous intensity 光照强度	IV	IF=60mA	L.S.L**)×0.7	--

**Notes:**

U.S.L.: Upper Standard Level

L.S.L.: Lower Standard Level

### Packaging Dimensions Specification(包装规格)

#### 1、Carrier tape dimensions(载带包装)

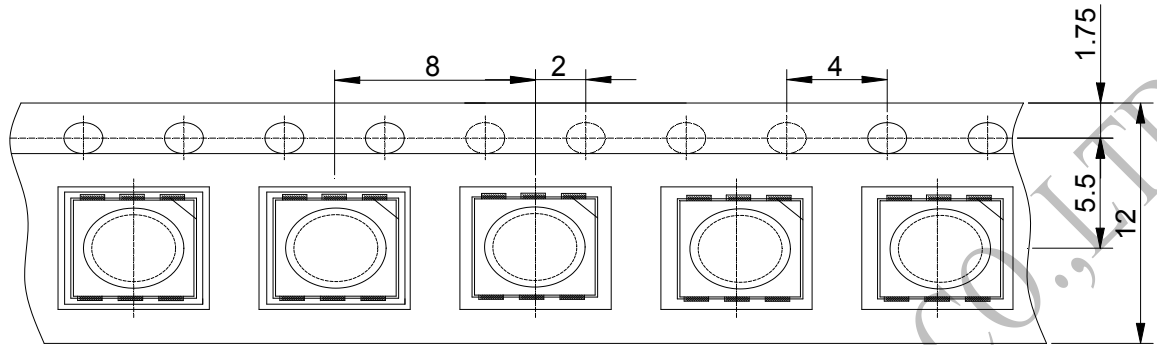

#### Notes:

- 1) .All dimensions are in millimeters;
- 2) .Tolerance is  $\pm 0.25$  unless otherwise noted.

#### Notes:

A、 empty tape; B、 loading tape; C、 empty tape.

#### 3、 Reel dimensions(带盘尺寸)

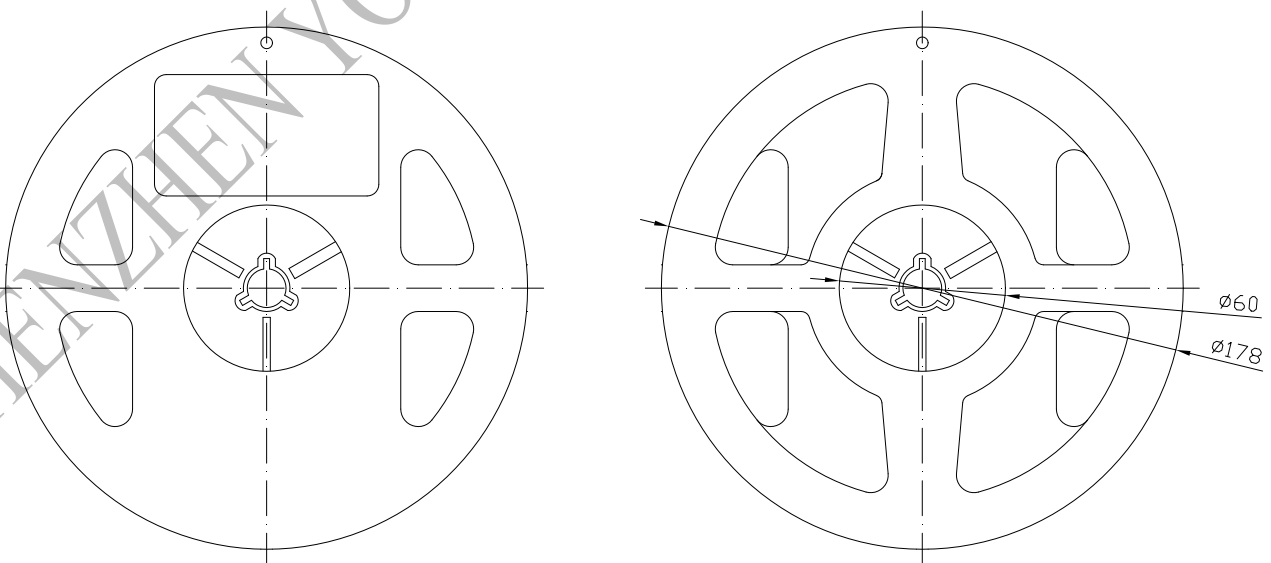

**Packaging Dimensions Specification(包装规格)**

**4、Moisture-Proof and anti-static electricity(防潮抗静电包装)**

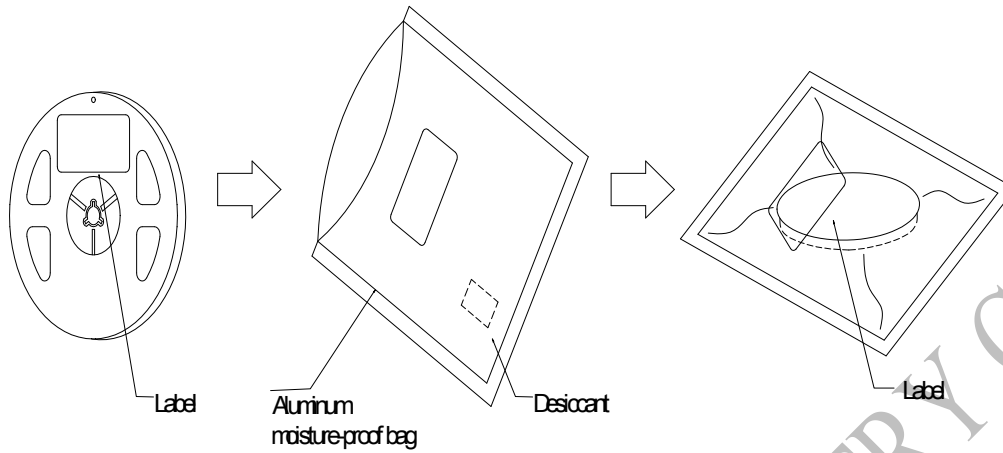

**5、Label(标签)**

深圳市永而佳实业有限公司	
SHENZHEN YONGERJIA INDUSTRY CO. <b>RoHS</b>	
Product No. :	*****
Part No. :	*****
C/T No. :	*****
BIN CODE :	*****
VF (V) :	*****
WD (nm) :	*****
IV (mcd) :	*****
Q' TY (PCS) :	*****
Lot No. :	*****
Tel: 86-755-29785600 Fax: 86-755-29785100	
Web: www. wej. cn	

**Label Explanation:**

VF	: Forward voltage (正向电压)
TC	: Color temperature (色温)
IV	: Luminous Intensity (亮度)



## SMD LED 使用说明

### Operating Instruction

使用场所：地板、桌面须防静电，机台仪器须接地，操作人员穿防静电服佩戴静电环，开启离子风机，地线必须和大地连通良好（连接大地处建议埋铜棒连接）。

Using place: The floor and desktop must be anti-static. The machine must be grounded and the operator should wear anti-static clothing & an electrostatic ring, ion fan need to be turned on, and the ground wire must be well connected to the ground (better to use copper rods).

#### 进料检验(Inspection)

检验环境：温度不高于 30℃，湿度不高于 60%RH。

Inspection environment: temperature not higher than 30℃, humidity not higher than 60%RH

在检验过程中人员必须穿防静电服、戴静电环和手套，检测仪器接地良好，在离子风机开启的情况下进行，抽检产品铝箔袋包装开封后 1 小时内完成检验，检验完成后应及时真空封口，抽检的材料做好标识区分并优先使用，避免产品受潮。

The inspection should be completed within 1 hour after packing is opened. After the inspection is finished, it should be vacuum sealed in time. The materials should be marked and be used priority to avoid the product from getting damp.

During the inspection, the inspector must wear anti-static clothing, electrostatic rings and gloves, and the testing equipment should be well grounded. The inspection should be done with the ion blower turned on.

#### 储存(Storage)

1. 产品所使用的支架为镀银支架，请客户特别注意产品的仓储、工作台面、设备表面、模具、人员等慎用含硫、含有腐蚀性的消毒剂（抗击疫情中较为常见使用的 84 消毒液其主要成分为次氯酸钠，而次氯酸钠具有较强的腐蚀性，接触 LED 器件会对器件产品的功能及长期寿命造成不可逆损伤），避免 LED 器件产品受到污染而导致产品不良和损失。

The LEDs is silver-plated bracket. Please pay attention to be cautious in using sulfur and corrosive disinfectants on the storage, work surface, equipment surface, mold, personnel etc. to avoid the pollution of the LED, lead to product failure and loss. (84 commonly used in the fight against COVID-19) The main component of the disinfectant sodium hypochlorite and sodium hypochlorite is highly corrosive. Touching with the LED device will cause irreversible damage to the function and long-term life)

2. 产品使用抽真空密封防潮铝箔袋包装，并附有干燥剂，湿敏指示卡，**最大程度上保证产品在一定期限内不会吸潮**，产品包装在开封前，储存在温度≤30℃,湿度≤60%RH 的环境中。

To the greatest extent, ensure that the product will not absorb moisture within a certain period of time, the LEDs should be stored at a temperature ≤ 30 °C, humidity ≤ 60% RH environment before packing is opened. The product is packing in a vacuum-sealed moisture-proof aluminum foil bag with a desiccant and moisture sensitive indicator card.

#### 使用(Usage)

1. 产品在拆袋除湿前请核对产品包装标签上的包装日期，按先进先出原则作业使用，如果在未拆包装袋前发现包装破损漏气胀气，真空失效的请退回我司。

Please check the packing date on the label before opening and dehumidifying, and use them according to the first-in-first-out principle. If the packing is found to be damaged and leaky before opening, please return back to us.

2. 产品开包时必须检查湿度卡是否正常，圆点标识蓝色为正常，30%圆点处变淡蓝色为已严重受潮，请退回我公司。

The humidity card must be checked whether it is normal once opening package. The dot indicates that blue is normal, If the 30% dot becomes light blue, LEDs The product already be severely damp, please return back to us

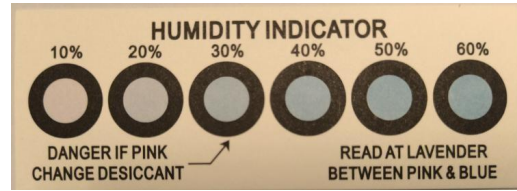
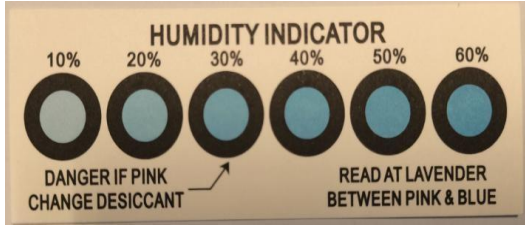

3. 产品 SMT 回流焊之前必须进行拆袋除湿，连同卷盘放到烤箱里面除湿，产品拆袋后需在 30 分钟内安排除湿作业，根据产能合理预估拆袋除湿数量，除湿条件：烤箱温度 65- 70℃,烘烤时间 24 小时；产品在除湿时请不要中途开关烤箱门，材料放置占烤箱总容积的 80%左右，材料不能挡住烤箱内出风口。

The product must be dehumidified before SMT reflow soldering, and placed in the oven together with the reel to dehumidify. After the product is unpacked, the dehumidification must be arranged within 30 minutes. The amount of dehumidification must be reasonably estimated according to the production capacity. The dehumidification condition: oven temperature 65- 70 °C , baking time for 24 hours; please do not open or close the oven door midway when the product is dehumidifying, the material should be placed about 80% of the total volume of the oven, and the material cannot block the air outlet in the oven



产品除湿完成后再按生产所需陆续取出灯珠使用，车间环境要求：温度 $\leq 30^{\circ}\text{C}$ ，湿度 $\leq 60\%RH$ 。

After completing dehumidification, the LEDs should be taken out according to using needs. The workshop environment requirements: temperature $\leq 30^{\circ}\text{C}$ , humidity $\leq 60\%RH$

4. 除湿完成后的灯珠在没上回流焊之前应储存在温度不高于  $30^{\circ}\text{C}$ ，湿度不高于  $30\%RH$  的环境中，并在 10 小时内完成回流焊作业，未用完的尾数，请累积（一个月）退回我公司。

The LEDs after dehumidifying should be stored in where the temperature is  $\leq 30^{\circ}\text{C}$  and the humidity is  $\leq 30\%RH$  before reflow soldering, and the reflow soldering operation should be completed within 10 hours. Please accumulate (one month) to return to us.

5. 未开封的产品须储存在温度不高于  $30^{\circ}\text{C}$ ，湿度不高于  $60\%RH$  的环境中，且 1 个月内用完。

The product should be kept at  $\leq 30^{\circ}\text{C}$  or humidity  $\leq 60\%RH$ , and be used within one month.

### SMT 回流焊说明(SMT Reflow Soldering Instructions):

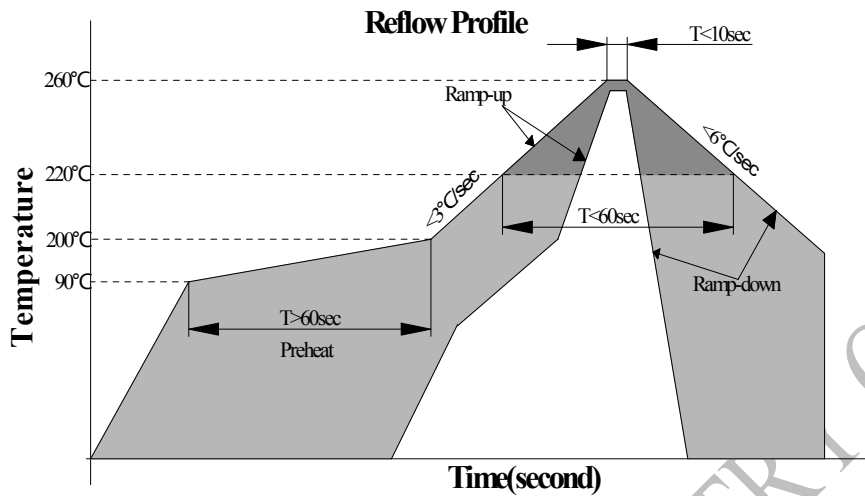

1. 回流焊不可以做两次以上 Reflow soldering should not be done more than two times.
2. 为保证产 LED 质量及可靠性，不可施加压力在 LED 表面。 Do not put pressure on the LEDs.
3. 在吸嘴的选取上要选择吸嘴的大小和压力合适的吸嘴，以避免造成压力过大伤害产品。

Please choose the right nozzle to avoid the damage to products due to the pressure

4. LED 为静电敏感产品，使用时请佩带防静电手环，工作台做好防静电处理，机台设备等保证接地。

Please put on the antistatic hand loop during the use. The worktable should be with antistatic finish. The equipments must be contacted with ground

### 手工焊接(Hand soldering):

1. 手工焊接时，要保持电烙铁温度在 350 摄氏度以下，并且焊接时间小于 3 秒，电烙铁不可接触胶体。

When hand soldering, keep the temperature of iron below less 300 °C less than 3 seconds. Electric soldering iron can not touch colloid

2. 手工焊接只可进行一次，重复焊接不保证产品是否完好。

Handwork soldering is only allowed once. We won't take responsibility for more than that.

3. 避免使用尖锐的物体直接接触产品胶体部分。

Avoid using sharp objects to compress products Colloidal Part directly

4. LED 为静电敏感产品，使用时请佩带防静电手环，工作台做好防静电处理，机台设备等保证接地。

Please put on the antistatic hand loop during the use. The worktable should be with antistatic finish. The equipments must be contacted with ground.

### 静电防护(Static electricity protection)

静电或电涌会导致产品特性发生改变，例如正向电压降低，如果情况严重甚至会损毁产品，所以在使用时必须采取有效的防静电措施；所有相关的设备和机器都应该正确接地，同时必须采取其他防止静电和电涌的措施，使用静电手环，防静电垫子，防静电工作服，工作鞋，手套，防静电容器，都是有效的防止静电和电涌的措施。

Static electricity or surge voltage damages the LEDs .Damaged LEDs will show some unusual characteristic such as the forward voltage comes lower, or the LEDs do not light at the low current .even not light.

All devices, equipment and machinery must be properly grounded. At the same time ,it is recommended that wrist bands or anti-electrostatic gloves, anti-electrostatic containers be used when dealing with the LEDs .

**眼睛防护(Safety advice for human eyes)**

LED 发光时，请勿直视发光光源，特别是对于一些光强较高的 LED，强光可能伤害你的眼睛。

Viewing direct to the light emitting center of the LEDs, especially those of great luminous Intensity will cause great hazard to human eyes .Please be careful.

**设计建议(Design consideration)**

设计带有 LED 产品的电路时，通过 LED 的电流不能超过规定的最大值，同时还需使用保护电阻，否则微小的电压变化将会引起较大的电流变化，可能导致产品损毁。

In designing a circuit about LED, the current through each LED must not exceed the absolute maximum rating specified for each LED. In the meanwhile, resistors for protection should be applied, otherwise slight voltage shift will cause big current change, burn out may happen.